

PWH100 系列/PWH100 Series

《產品介紹 note》：

產品編碼 Code No.	活塞直徑 Piston Diameter	倍比 Ratio	吐出量(往返一次) Fluid volume for cycle (cc./cycle)	耗氣量(往返一次) Consumption for cycle (L/cycle)
PWH100011	Ø100	11	70	4.17
PWH100024	Ø100	24	30	4.40
PWH100038	Ø100	38	20	4.47
PWH100006-U	Ø100	6	62	4.22
PWH100016-U	Ø100	16	24	4.44
PWH100025-U	Ø100	25	15	4.50
PWH100038-U	Ø100	38	10	4.53
PWH100012-UD	Ø100	12	62	8.12

外觀尺寸 Dimensional Features(單位:mm)

PWH100U-U 系列

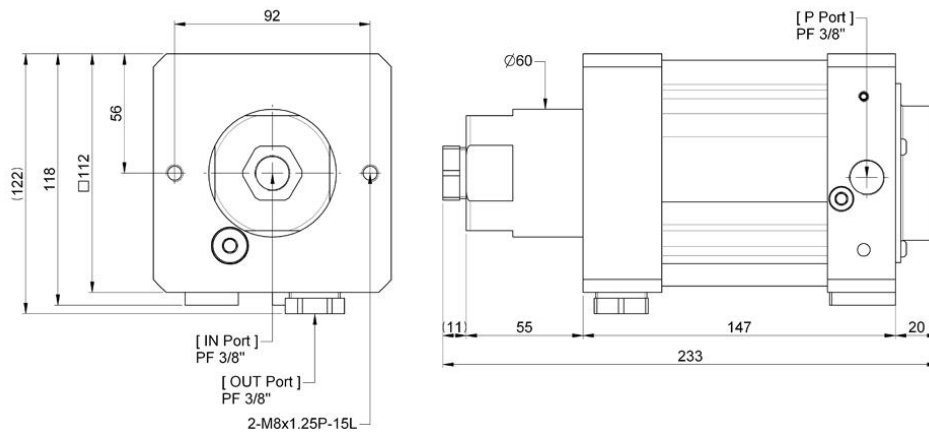

PWH100UD 系列

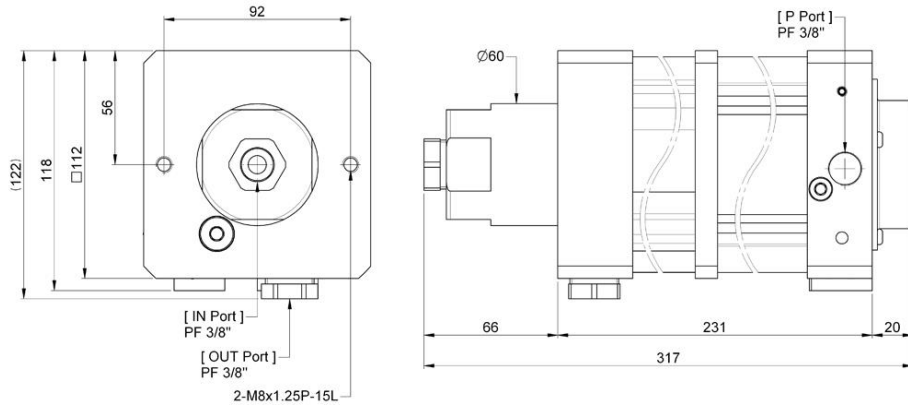

PWH100 系列

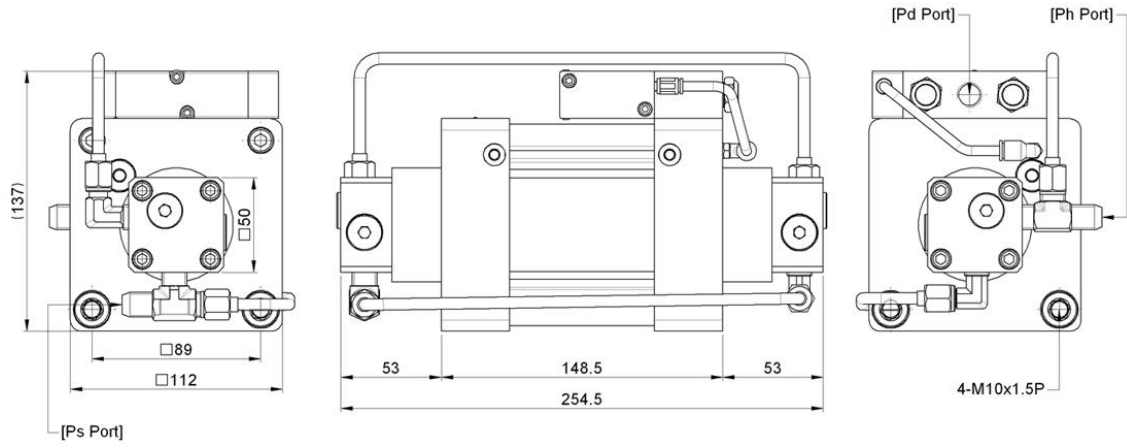

PW150005TE/PW150008TE/PW150009E/PW150014E/PW150015TE/PW150025E(電磁閥起動)

