

valves

L2 Series

Solenoid Pilot, Air Pilot or Hand Lever Actuated Valves



numatics®

Table of Contents



L2 Series	3-14
Technical and Operating Data	3-4
How to Order	5
Valve Dimensions	6-7
Manifold Assemblies	8-9
Hand Lever Valves	10
Speed Control Kit	11
Valve Service Kits and Parts	12-13
Internal/External Pilot Selection	14
Blank Station Plate Kit	14
Adaptor Kit	14
Blocking Plug Kit	14
Solenoid Assemblies	14



single solenoid
2 position 4-way

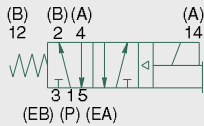

double solenoid pilot
2 position 4-way

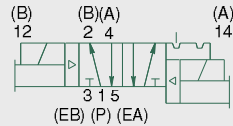

double solenoid pilot
3 position 4-way
open center

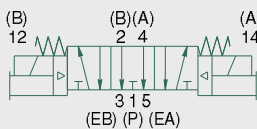

double solenoid pilot
3 position 4-way
closed center

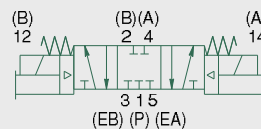

single air pilot
2 position 4-way
no override

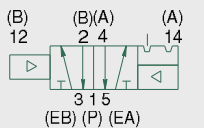

single air pilot
2 position 4-way
no override

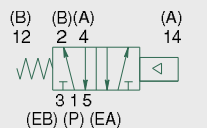

double air pilot
3 position 4-way
closed center
no override

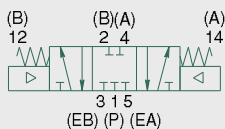

double air pilot
3 position 4-way
open center
no override

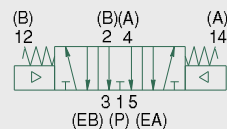

single air pilot
2 position 4-way
w/override

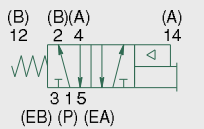

double air pilot
2 position 4-way
w/override

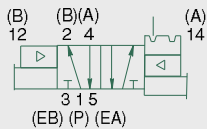

double air pilot
3 position 4-way
open center w/override

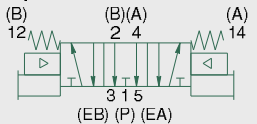

double air pilot
3 position 4-way
closed center w/override

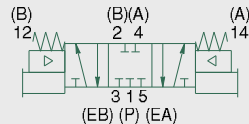

double air pilot
2 position 4-way
spring offset
no override

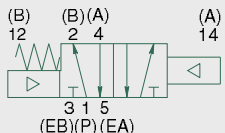

double solenoid pilot
3 Position 4-Way (5/3),
open to 4 (A) and
2 (B) in center

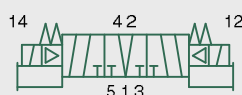

5 Ported, 2 and 3 position, 4-way, Spool & Sleeve
Cv: 1.7

- Solenoid pilot or air pilot actuated
- Hand-lever valves available
- DIN plug-in solenoid and plug connector with indicator light
- Unlubricated or lubricated service
- In-line or manifold mounted
- Integral speed control available



hand lever
2 position 4-way
w/spring return

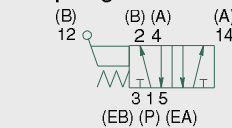

hand lever
2 position 4-way
w/detent

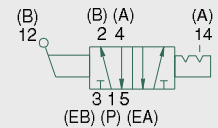

hand lever
3 position 4-way
open center
w/spring center

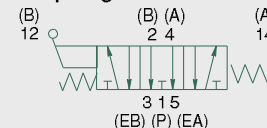

hand lever
3 position 4-way
open center
w/detent

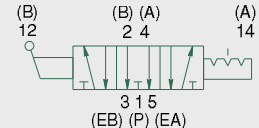

hand lever
3 position 4-way
closed center
w/spring center

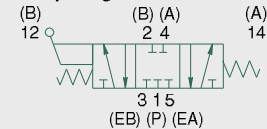

hand lever
3 position 4-way
closed center
w/detent

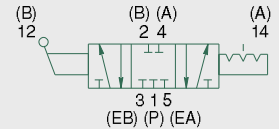

double air pilot
3 Position 4-Way (5/3),
open to 4 (A) and
2 (B) in center

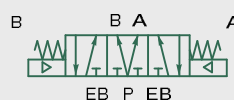

double air pilot
3 Position 4-Way (5/3),
open to 4 (A) and
2 (B) in center





L2 Series

Technical Data

VALVE DATA	ENGLISH		METRIC	
Cv	1/4 = 1.7	3/8 = 1.7	1/4 = 1.7	3/8 = 1.7
Flow capacity	79 SCFM @ 80 PSIG upstream pressure to atmosphere		1674 NI/m @ 6 bar upstream/5 bar downstream	
Main Valve Operating Pressure Range	28" HG. Vacuum to 150 PSIG		Vacuum to 10 bar	
Pilot Pressure Range: Internal and External	14.5 to 150 PSIG		1 to 10 bar	
Temperature range: Solenoid Pilot (ambient)	-10°F to +115°F		-23°C to +46°C	
Temperature Range: Air Pilot (ambient)	-10°F to +150°F		-23°C to +66°C	

Operating Data

ALL SOLENOIDS ARE CONTINUOUS DUTY RATED		12 VDC	24 VDC	24 VAC 50 Hz	24 VAC 60 Hz	115 VAC 50 Hz	120 VAC 60 Hz	230 VAC 50 Hz	240 VAC 60 Hz
Power (Watts)*		3.5	3.5	4.8	3.3	4.8	4.0	5.0	3.5
Holding Current (Amps.)		0.30	0.15	0.380	0.280	0.064	0.054	0.030	0.023
Inrush Current (Amps.)		N/A	N/A	0.500	0.420	0.087	0.082	0.042	0.036
Energize in seconds	2-Position, Single, Spring Return	0.010	0.010	0.007	0.007	0.007	0.007	0.007	0.007
	2-Position, Double, Detented	0.010	0.010	0.007	0.007	0.007	0.007	0.007	0.007
	3-Position, Spring Centered	0.010	0.010	0.007	0.007	0.007	0.007	0.007	0.007
De-energize in seconds	2-Position, Single, Spring Return	0.035	0.035	0.035	0.035	0.035	0.035	0.035	0.035
	2-Position, Double, Detented	N/A	N/A	N/A	N/A	N/A	N/A	N/A	N/A
	3-Position, Spring Centered	0.030	0.035	0.035	0.035	0.035	0.035	0.035	0.035

*A 1.4 Watt DC solenoid is available. Add "17G" to the model number. **EXAMPLE:** L22BA452B017G61. Maximum pilot pressure is reduced to 116 PSIG (8 bar).



How to Order

Valves

L22 JA 4 52 O 0 000 00

<p>Valve Series & Port Size L22 = 1/4 L23 = 3/8</p> <p>Valve Type BA = Single Solenoid Pilot, Spring Return w/Flush Locking Override BB = Double Solenoid Pilot w/Flush Locking Override PA = Single Air Pilot Cap w/Spring Return PP = Double Air Pilot Cap PM = Double Air Pilot w/Spring Offset JA = Single Air Pilot w/Flush Non-locking Override and Spring Return JJ = Double Air Pilot w/Flush Non-locking Override LA = Hand Lever w/Spring Return LD = Hand Lever w/Detent</p> <p>Function 4 = 2 Position, 4-Way 5 = 3 Position, 4-Way Open Center 6 = 3 Position, 4-Way Closed Center 7 = 3 Position 4-Way (5/3), Open to 4 (A) and 2 (B) in Center</p> <p>Mounting 52 = Line Mounted</p>	<p>Voltage 20 = 24/50-60 VAC 30 = 110-120/50-60 VAC 40 = 220-240/50-60 VAC 60 = 12 VDC 61 = 24 VDC 00 = N/A (Use With Air Pilot or Hand Lever)</p> <p>Options 14A = External Pilot Supply 17G = Low Watt Solenoid – 1.42 Watt 17P = Flush Non-locking Override 18D = Side Ports (see p. 6)</p> <p>Port Type O = NPTF G = G Tap</p> <p>Wiring Option B = DIN Plug-in DC Solenoid O = DIN Plug-in AC Solenoid or Air Pilot or Handlever</p>
---	---

NOTE: Plug connector is NOT included with DIN solenoid. Order plug-in connector assembly separately (see ordering information below)

Plug Connector Assemblies

Per DIN Spec. NO 43650. Accepts cable diameter 0.240 to 0.310
11mm Industry Standard DIN Form B

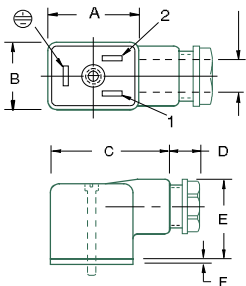

PLUG CONNECTOR DESCRIPTION	PART NO.
Grey (14 end solenoid) Plug Assembly	230-363
Black (12 end solenoid) Plug Assembly	230-364
Plug Assembly with 24 V Light	230-365
Plug Assembly with 110 V Light	230-366
Plug Assembly with 220 V Light	230-367

Dimensions

top dimensions = inches and bottom dimensions (in parenthesis) = millimeters

A	B	C	D	E	F
1.12 (28.4)	0.83 (21.1)	1.57 (39.9)	0.40 (10.2)	1.10 (28.4)	0.06 (1.5)

Manifold Assembly

AK 0 3 D 0000 3 N STD

<p>Electrical/Electronics Type & Location 0 = Standard</p> <p>Valve Line 3 = L2 Series</p> <p>Number of Valve Stations B = 2 F = 6 J = 10 C = 3 G = 7 K = 11 D = 4 H = 8 L = 12 E = 5 I = 9</p>	<p>Options Std = Standard (Common Supply and Exhaust) A19 = Common Supply, Individual Exhaust</p> <p>Port Type N = NPTF G = G Tap</p> <p>End Plate Port Size 3 = 3/8</p>
---	---

Example order:

Assembly Kit:	AK03D00003NSTD
Station 1	L23BB552O000030
Station 2	L23BA452O000030
Station 3	L23PP452O000000
Station 4	L23PA452O000000
	ASSEMBLED



L2 Series

Solenoid-Pilot Valve

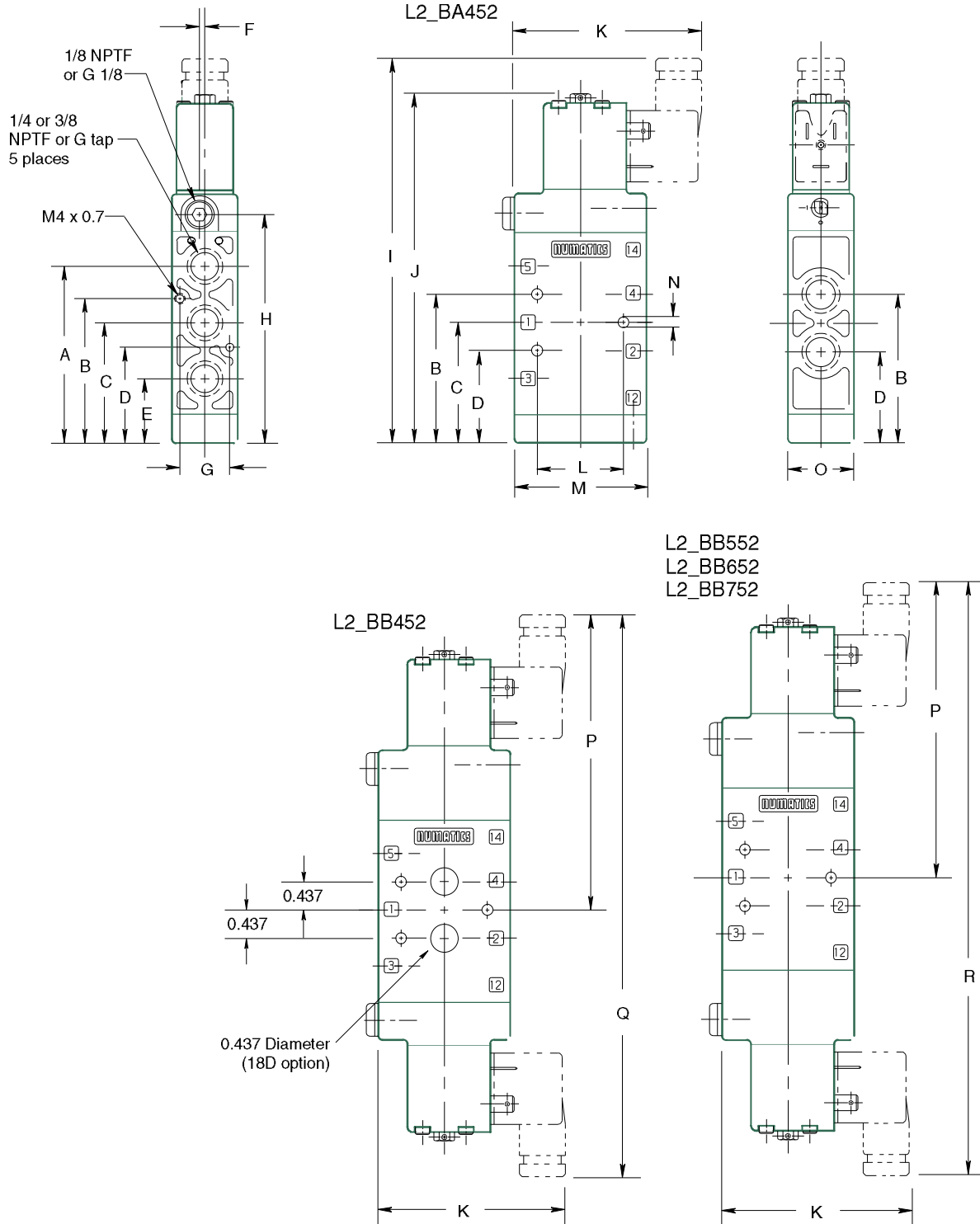

Dimensions

top dimensions = inches and bottom dimensions (in parenthesis) = millimeters

A	B	C	D	E	F	G	H	I	J	K	L	M	N	O	P	Q	R
2.72	2.28	1.85	1.41	0.97	0.08	0.75	3.53	5.99	5.38	2.89	1.27	2.00	0.17	1.00	4.66	8.78	9.32
(69.1)	(57.9)	(47.0)	(35.8)	(24.6)	(2.0)	(19.1)	(89.7)	(152.1)	(136.7)	(72.9)	(32.3)	(50.8)	(4.3)	(25.4)	(118.4)	(223.0)	(236.7)



Air-Pilot Valve - 2 Position L2_PA425, L2_JA452

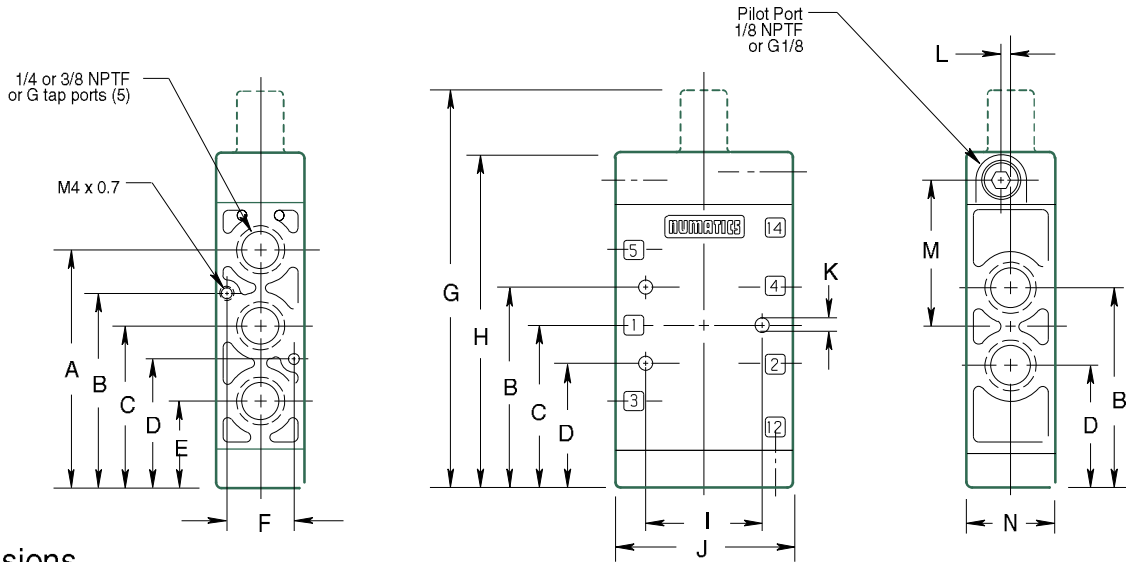

Dimensions

top dimensions = inches and bottom dimensions (in parenthesis) = millimeters

A	B	C	D	E	F	G	H	I	J	K	L	M	N
2.72 (69.1)	2.28 (57.9)	1.85 (47.0)	1.41 (35.8)	0.97 (24.6)	0.75 (19.1)	4.56 (115.8)	3.85 (97.8)	1.27 (32.3)	2.00 (50.8)	0.17 (4.3)	0.08 (2.1)	1.69 (42.9)	1.00 (25.4)

Air-Pilot Valve L2_PP452, L2_PP552, L2_PP652 L2_PP752, L2_PM452, L2_JJ452 L2_JJ552, L2_JJ652, L2_JJ752

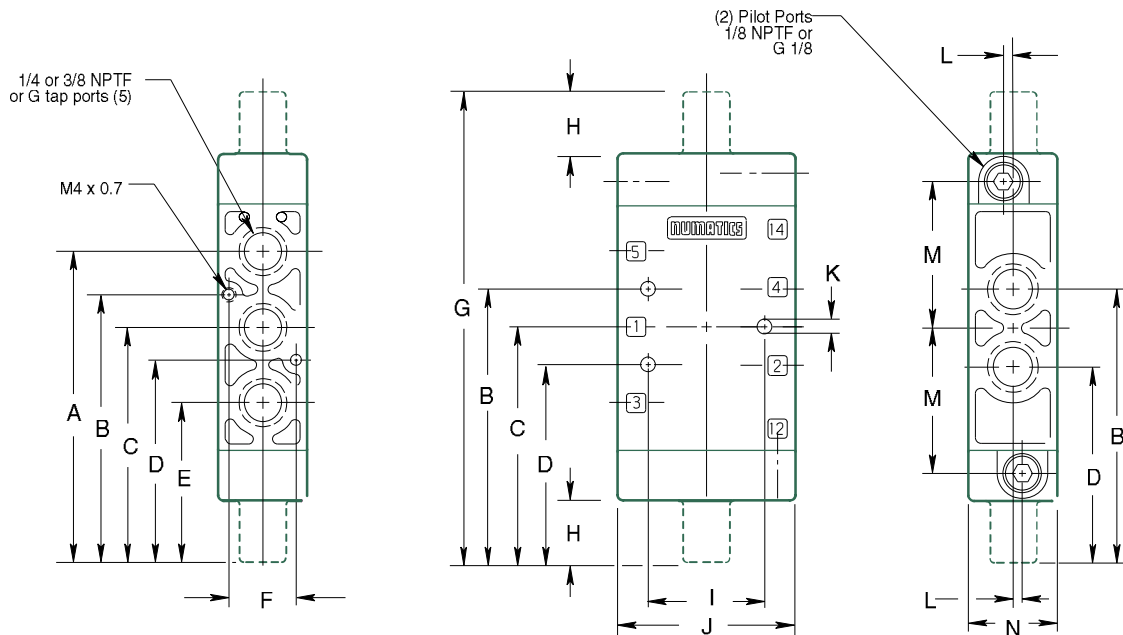

Dimensions

top dimensions = inches and bottom dimensions (in parenthesis) = millimeters

A	B	C	D	E	F	G	H	I	J	K	L	M	N
3.59 (91.2)	3.15 (79.9)	2.71 (68.8)	2.28 (57.8)	1.84 (46.6)	0.75 (19.1)	5.43 (137.9)	0.71 (18.0)	1.27 (32.3)	2.00 (50.8)	0.17 (4.3)	0.08 (2.1)	1.69 (42.9)	1.00 (25.4)



L2 Series

Manifold Assembly Common Supply and Exhaust

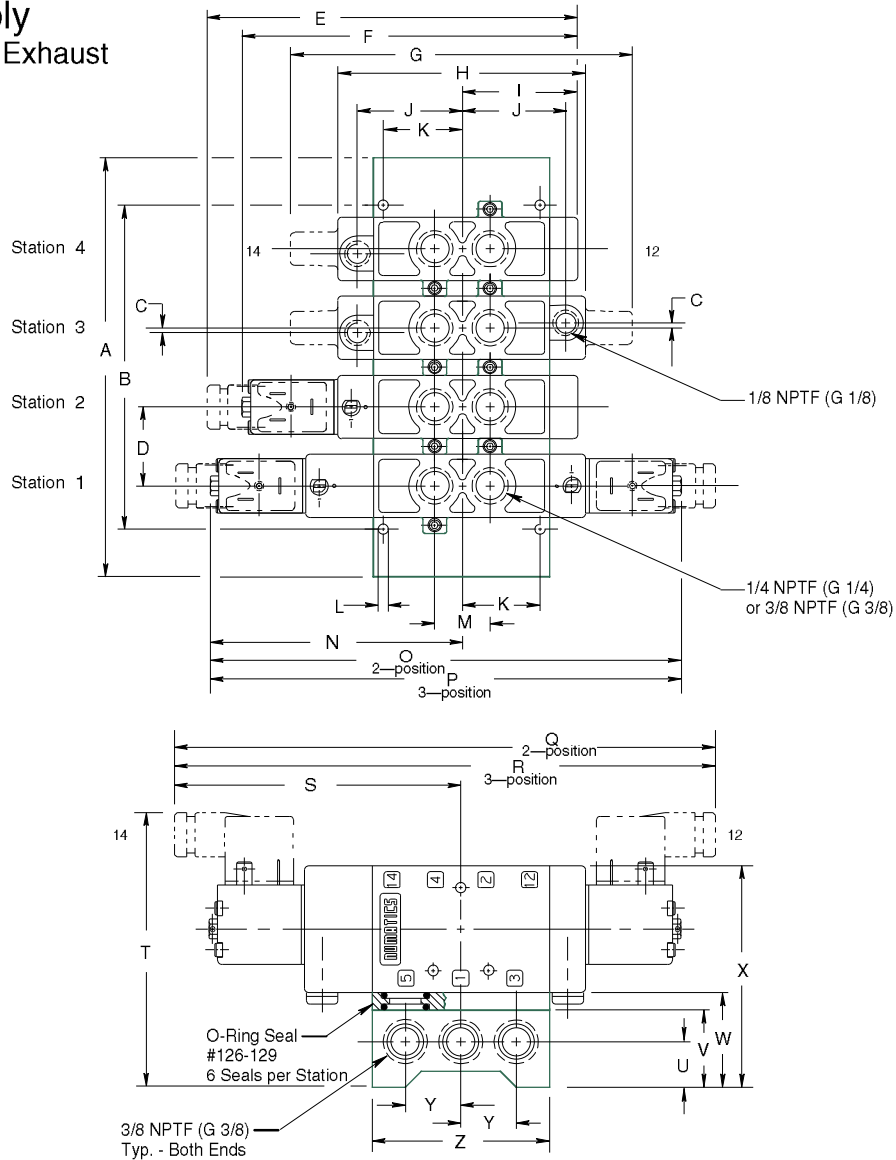

Dimensions

top dimensions = inches and bottom dimensions (in parenthesis) = millimeters

A	B	C	D	E	F	G	H	I	J	K	L	M	N	O	P
See Chart Below	See Chart Below	0.08 (2.0)	1.26 (32.0)	5.99 (152.1)	5.38 (136.6)	5.43 (137.9)	4.01 (101.9)	1.85 (47.0)	1.69 (42.9)	1.25 (31.8)	0.16 (4.1)	0.88 (22.4)	4.05 (102.9)	7.58 (192.5)	8.10 (205.7)

Q	R	S	T	U	V	W	X	Y	Z
8.78 (223.0)	9.32 (236.7)	4.66 (118.4)	4.35 (110.5)	0.72 (18.3)	1.20 (18.3)	1.48 (37.6)	3.48 (88.4)	0.88 (22.4)	2.78 (70.6)

MANIFOLD # STATIONS	DIM A	DIM B	3/8 NPTF PART NO.	G 3/8 PART NO.	MANIFOLD # STATIONS	DIM A	DIM B	3/8 NPTF PART NO.	G 3/8 PART NO.
2 Stations	4.16 (105.7)	2.64 (67.1)	106-704	106-715	8 Stations	11.72 (299.7)	10.20 (259.1)	106-710	106-721
3 Stations	5.42 (137.7)	3.90 (99.1)	106-705	106-716	9 Stations	12.98 (329.7)	11.46 (291.1)	106-711	106-722
4 Stations	6.68 (169.7)	5.16 (131.1)	106-706	106-717	10 Stations	14.24 (361.7)	12.72 (323.1)	106-712	106-723
5 Stations	7.94 (201.7)	6.42 (163.1)	106-707	106-718	11 Stations	15.50 (393.7)	13.98 (355.1)	106-713	106-724
6 Stations	9.20 (233.7)	7.68 (195.1)	106-708	106-719	12 Stations	16.76 (425.7)	15.24 (387.1)	106-714	106-725
7 Stations	10.46 (265.7)	8.94 (227.1)	106-709	106-720	Adaptor Kit	Order (1) adaptor kit for each station on the manifold. Includes all seals and screws.			239-312



Manifold Assembly Common Supply and Individual Exhaust

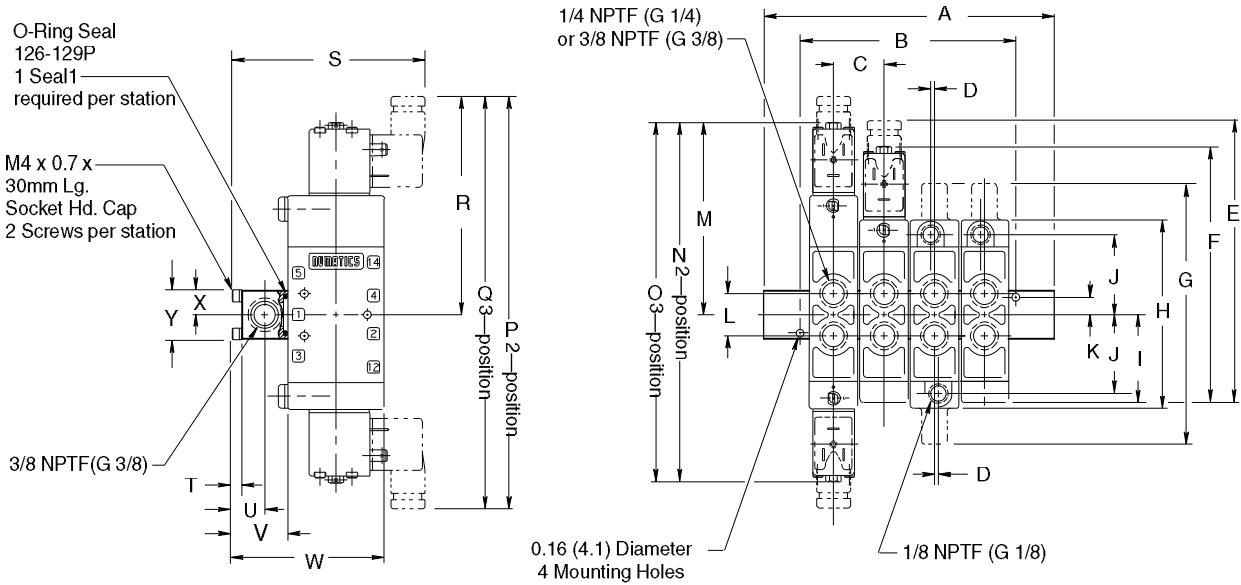

Dimensions

top dimensions = inches and bottom dimensions (in parenthesis) = millimeters

A	B	C	D	E	F	G	H	I	J	K	L	M	N	O	P
See Chart Below	See Chart Below	1.03 (26.2)	0.08 (2.1)	5.99 (152.1)	5.38 (136.6)	5.43 (137.9)	4.01 (101.9)	1.85 (46.9)	1.69 (42.9)	0.38 (9.5)	0.88 (22.2)	4.05 (102.9)	7.58 (192.6)	8.10 (205.7)	8.78 (223.0)
Q	R	S	T	U	V	W	X	Y							
9.32 (236.7)	4.66 (118.4)	3.77 (95.8)	0.20 (5.2)	0.45 (11.4)	0.90 (22.9)	3.10 (78.9)	0.48 (12.3)	0.97 (24.6)							

MANIFOLD # STATIONS	DIM A	DIM B	3/8 NPTF PART NO.	G 3/8 PART NO.
2 Stations	3.92 (99.2)	2.40 (60.9)	229-946	229-957
3 Stations	4.95 (125.7)	3.43 (87.1)	229-947	229-958
4 Stations	5.98 (151.9)	4.46 (113.3)	229-948	229-959
5 Stations	7.01 (178.1)	5.49 (139.5)	229-949	229-960
6 Stations	8.04 (204.2)	6.52 (165.6)	229-950	229-961
7 Stations	9.07 (230.4)	7.55 (191.8)	229-951	229-962

MANIFOLD # STATIONS	DIM A	DIM B	3/8 NPTF PART NO.	G 3/8 PART NO.
8 Stations	10.10 (256.5)	8.58 (217.9)	229-952	229-963
9 Stations	11.13 (282.7)	9.61 (244.1)	229-953	229-964
10 Stations	12.16 (308.9)	10.64 (270.3)	229-954	229-965
11 Stations	13.16 (335.0)	11.67 (296.4)	229-955	229-966
12 Stations	14.22 (361.2)	12.70 (322.6)	229-956	229-967



L2 Series

Hand Lever Valve

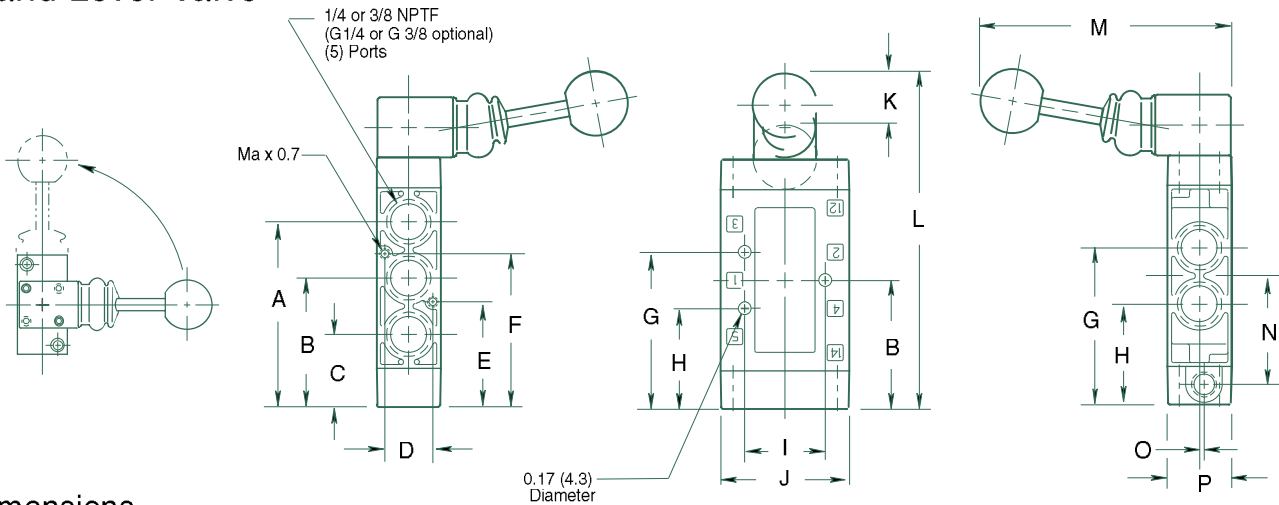

Dimensions

top dimensions = inches and bottom dimensions (in parenthesis) = millimeters

A	B	C	D	E	F	G	H	I	J	K	L	M	N	O	P
2.88 (73.2)	2.00 (50.8)	1.13 (28.7)	0.75 (19.1)	1.63 (41.4)	2.38 (60.5)	2.44 (62.0)	1.57 (39.9)	1.27 (32.3)	2.00 (50.8)	0.72 (18.3)	5.18 (131.6)	3.93 (99.8)	1.68 (42.7)	0.08 (2.0)	1.00 (25.4)

Lever Rotation Procedure

The Numatics L22&L23 Hand Lever Series allows for the rotation of the lever 90° to become parallel with the valve cylinder ports.

Remove (2) M3 socket head screws from lever bracket and rotate 90° in either direction. Re-assemble screws and tighten securely.

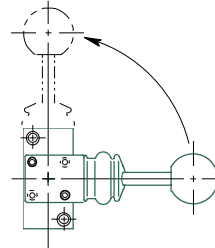

Hand Lever Valve Manifold Assembly

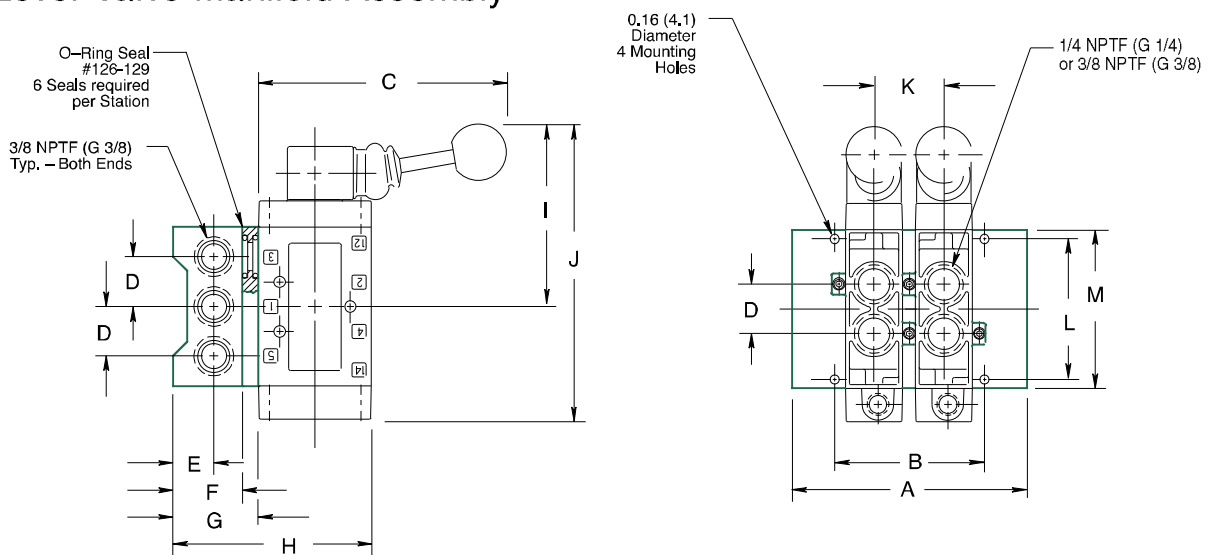

Dimensions

top dimensions = inches and bottom dimensions (in parenthesis) = millimeters

A	B	C	D	E	F	G	H	I	J	K	L	M
See chart on pg. 6	See chart on pg. 6	4.43 (112.5)	0.88 (22.4)	0.72 (18.3)	1.20 (30.5)	1.48 (37.6)	3.48 (88.4)	3.18 (80.8)	5.18 (131.6)	1.26 (32.0)	2.49 (63.2)	2.78 (70.6)



L2 Series

Speed Control Kit

239-209

The L2 speed control mounts between any L2 Series valve and die cast adaptor using (3) O-rings from the speed control kit and (3) O-rings and (2) screws from the adaptor kit. This assembly then mounts to and 3-gallery manifold by using the remaining (3) O-rings and (2) screws from the adaptor kit.

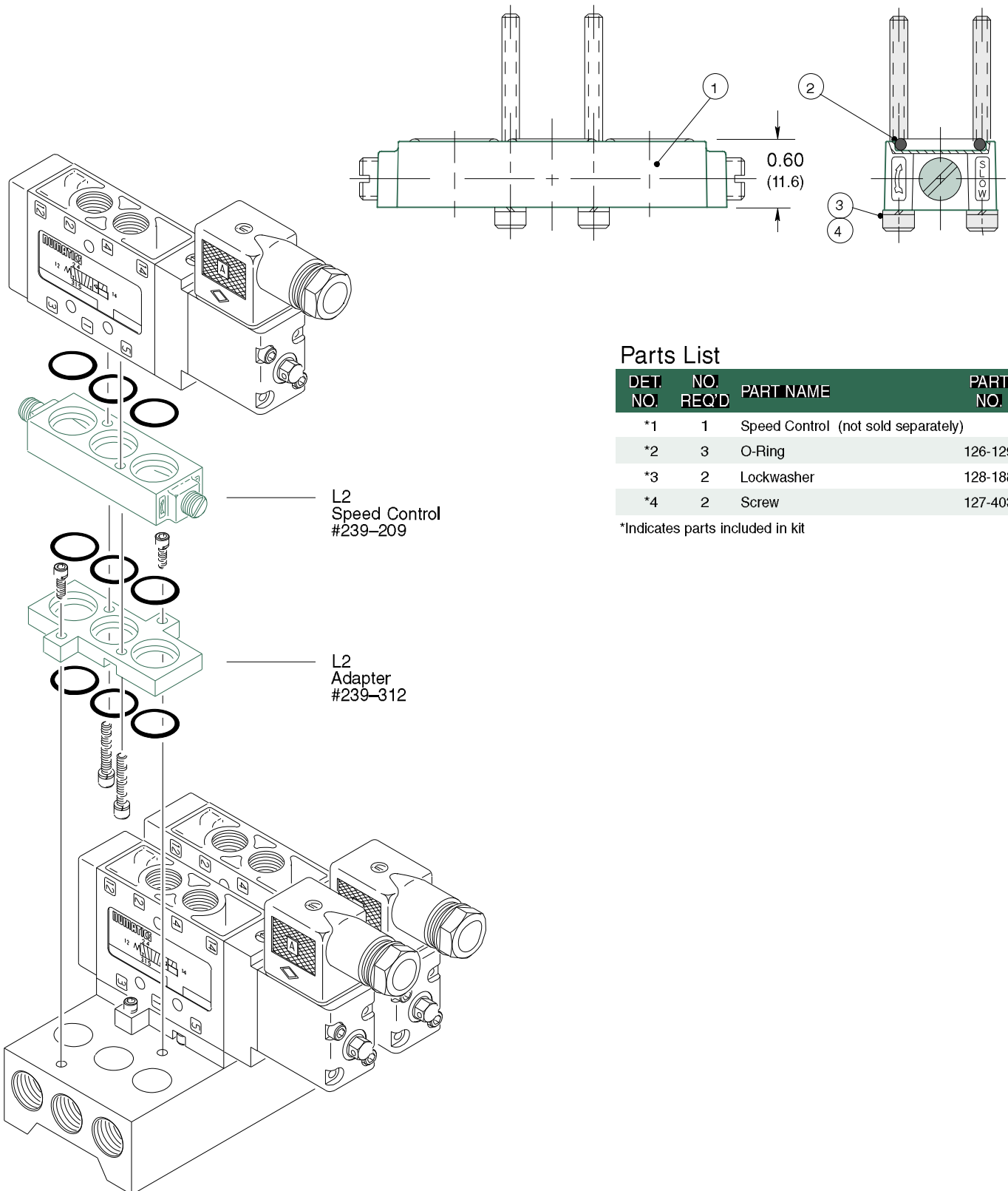

Parts List

DET. NO.	NO. REQ'D	PART NAME	PART NO.
*1	1	Speed Control (not sold separately)	
*2	3	O-Ring	126-129
*3	2	Lockwasher	128-188
*4	2	Screw	127-403

*Indicates parts included in kit



L2 Series

Valve Service Kits and Parts – 2 Position

Solenoid-Pilot Actuated

Kit No. L2-K1 (For Models L22BA4, L23BA4)

Kit No. L2-K2 (For Models L22BB4, L23BB4)

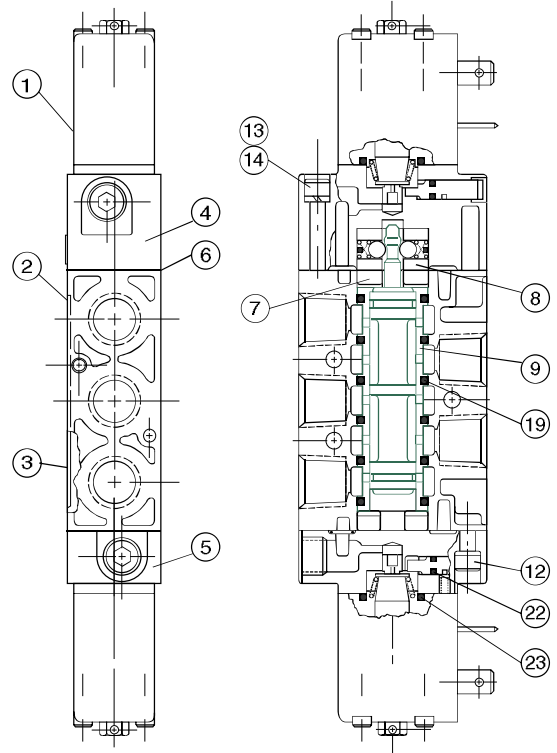
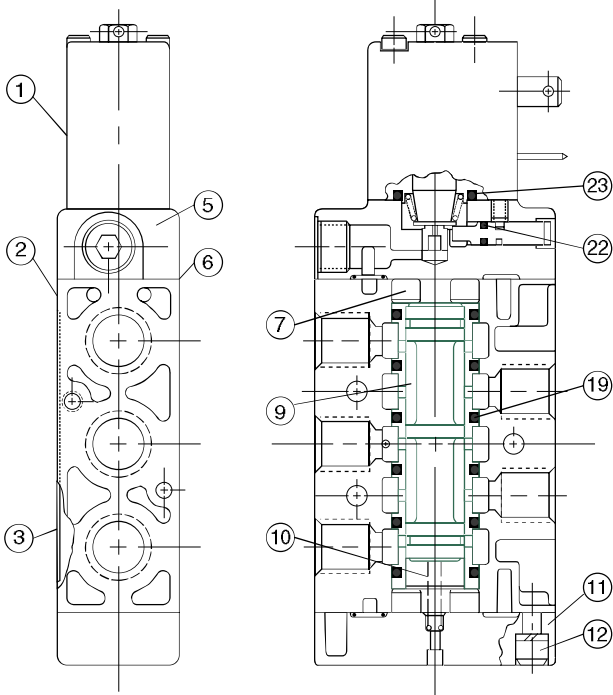

Air-Pilot Actuated

Kit No. L2-K1 (For Models L2_PA4, L2_JA4)

Kit No. L2-K2 (For Models L2_PP4, L2_JJ4)

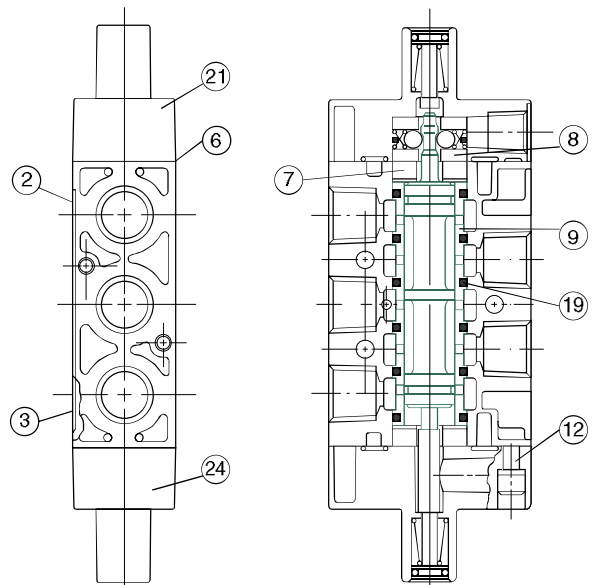
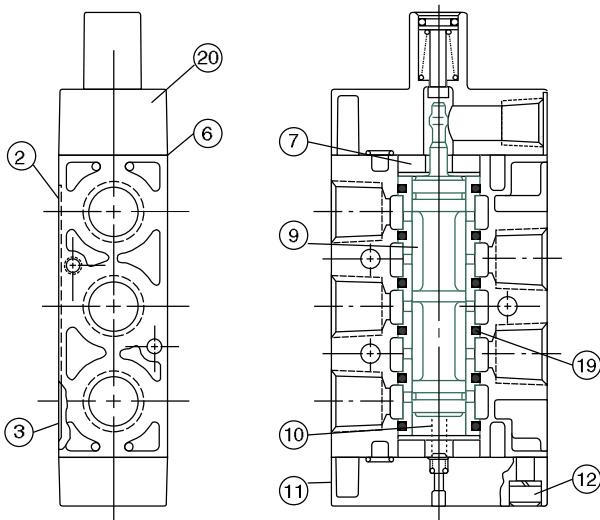



Valve Service Kits and Parts – 3 Position

Solenoid-Pilot Actuated

Kit No. L2-K3 (For Models L2_BB5, L2_BB6, L2_BB7)

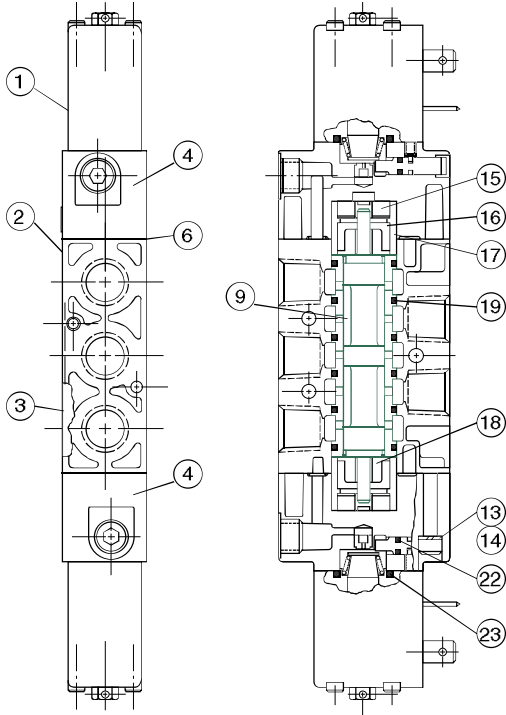

Parts List

DET. NO.	NO. REQ'D	PART NAME	PART NO.
1	1	Solenoid Capsule Assembly	See p. 14
2	1	Valve Body (not sold separately)	
3	1	Nameplate	122-940
4	>	Adaptor Assembly	219-129
5	1	Adaptor Assembly	219-127
6 *	2	Gasket	113-313
7 ~	2	Bumper	114-147
8 ***	1	Detent Assembly	210-116
9	1	Sleeve Assembly w/Seals † for models: L2-BA4 L2-BB4, JA4, PA4 L2-BB5, JJ5, PP5 L2-BB6, JJ6, PP6 L2-BB7, JJ7, PP7	209-323 209-327 209-370 209-371 209-372
1† **	1	Spring	115-248
11	1	Spring Cover Assembly	204-393
12	<	Screw Assembly	127-396
13	•	Lockwasher	128-190
14	2	Screw	127-400
15****	2	Bumper	114-148
1†****	2	Spring	115-247
17****	2	Spacer	116-341
1†****	2	Spring Retainer	116-340
19*	6	O-Ring Seal	126-204
20	1	Pilot Cap Assembly	204-404
21	>	Pilot Cap Assembly	204-408
2† *	2	Seal (override)	126-163
23*	2	Seal (solenoid-pilot)	126-203
24	1	Pilot Cap Assembly	204-406

Air-Pilot Actuated

Kit No. L2-K3 (For Models L2_PP5, L2_PP6, L2_PP7, L2_JJ5, L2_JJ6, L2_JJ7)

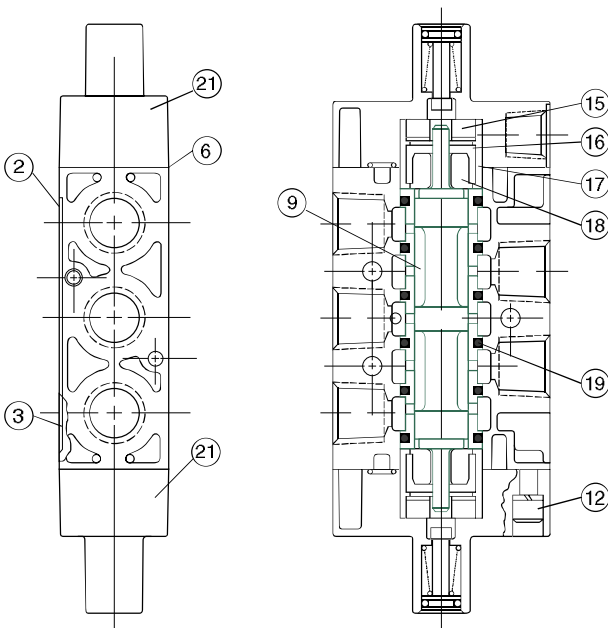

* indicates parts in L2-K1, L2-K2, and L2-K3

** indicates part in L2-K1 only

*** indicates part in L2-K2 only

**** indicates part in L2-K3 only

~ indicates part in L2-K1 and L2-K2 only

† Spool & sleeve assemblies are precision matched sets & include (6) 126-204 seals; spools are not interchangeable.

> (1) for 2-position models; (2) for 3-position models

< (4) for L2-BA4, (2) for L2-BB4

• (2) for 2-position models; (4) for 3-position models



L2 Series

Internal / External Pilot Selection

INTERNAL
PILOT SUPPLY

EXTERNAL
PILOT SUPPLY

NOTE: On double solenoid-pilot valves, both ends must be converted.

External pilot supply must be used if pressure is supplied to any port except No.1.

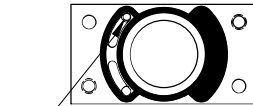

PILOT SUPPLY HOLE MUST BE VISIBLE BOTH ENDS



ROTATE GASKET TO COVER PILOT SUPPLY HOLE. REMOVE PIPE PLUG (PART NO. 129-100)

Blank Station Plate Kit

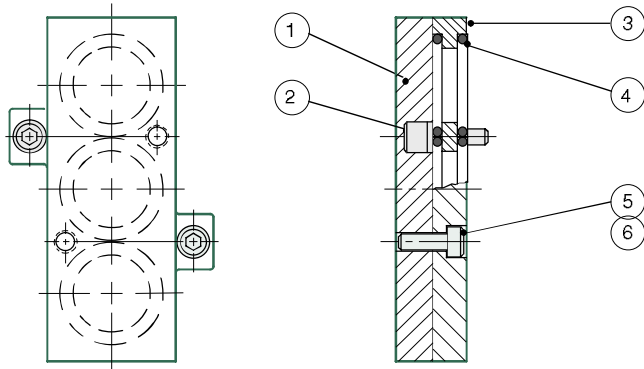

MANIFOLD TYPE	PART NO.
---------------	----------

Common Supply, Common Exhaust (shown)	239-471
Common Supply, Individual Exhaust (not shown)	229-990

Parts List

DET. NO.	NO. REQ'D	PART NAME	239-471 PART NO.	229-990 PART NO.
1 *	1	Blank Station Plate (not sold separately)		
2 *	2	Screw Assembly	127-570	N/A
3 *	1	Adaptor (not sold separately)		
4 *	6	O-Ring	126-129	126-129
5 *	2	Screw	127-710	127-361
6 *	2	Lockwasher	128-190	128-188

*Indicates parts included in kit

Adaptor Kit

239-312

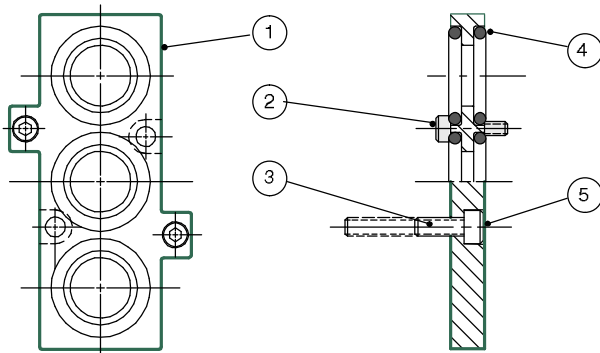

Parts List

DET. NO.	NO. REQ'D	PART NAME	PART NO.
1 *	2	Adaptor (not sold separately)	
2 *	2	Screw	127-577
3 *	2	Screw	127-570
4 *	6	O-Ring	126-129
5 *	2	Screw (shipped loose)	127-400

*Indicates parts included in kit

Blocking Plug Kit

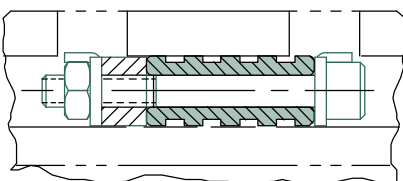

MANIFOLD TYPE	PART NO.
---------------	----------

Common Supply, Common Exhaust (shown)	239-516
Common Supply, Individual Exhaust (not shown)	239-250

Kit includes (2) blocking plug spacer, rubber spacer, nut and screw

Solenoid Assemblies

STANDARD VOLTAGES	100-115/50 115-120/60 VAC	200-240/50 220-240/60 VAC	24/50-60	12 VDC	24VDC
Part No.	237-569	237-570	237-568	226-737	226-749